

Treasure chest

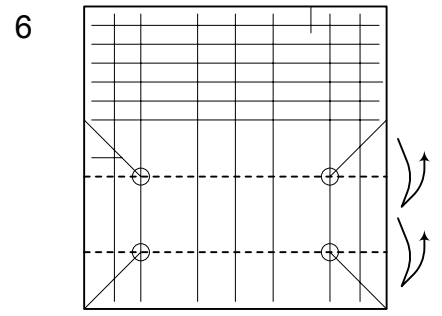

Make 2 valley folds using circled reference points

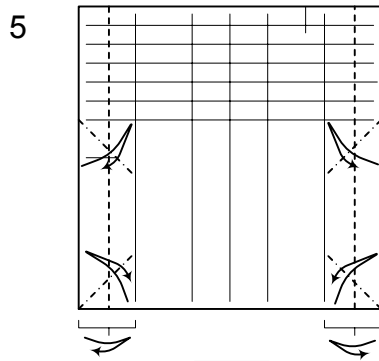
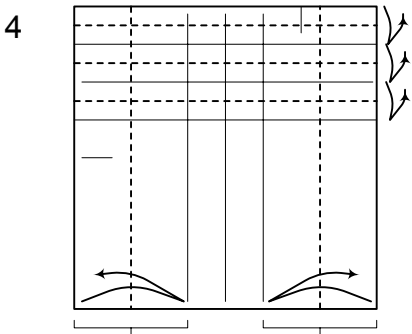
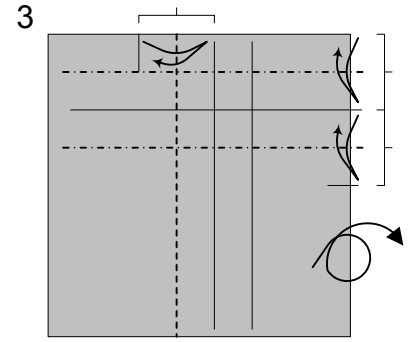
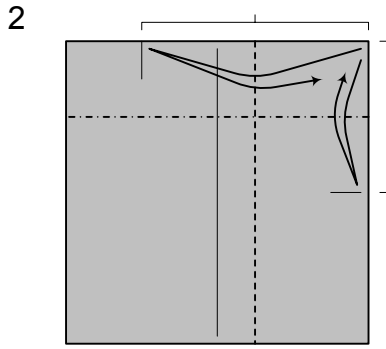
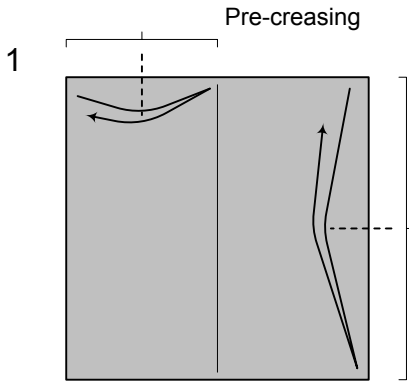
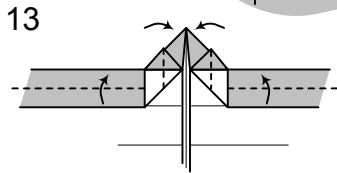
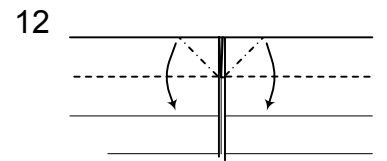
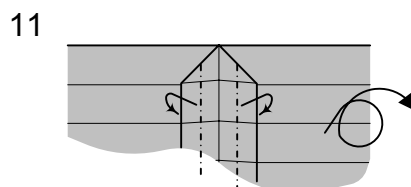
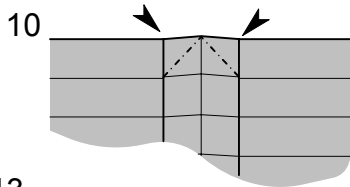
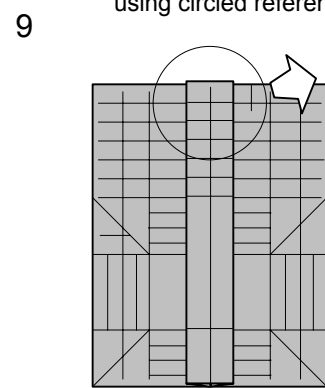
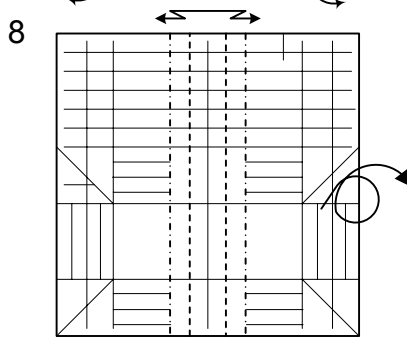
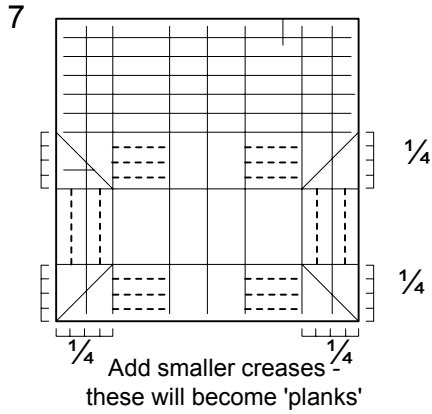

Swivel fold the edges

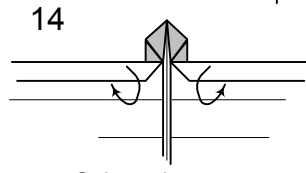

Colour change

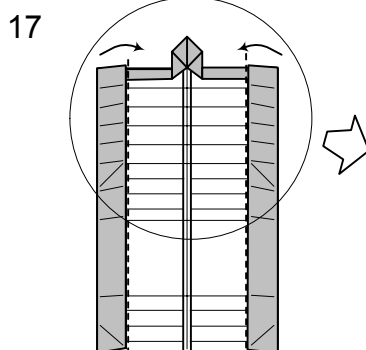
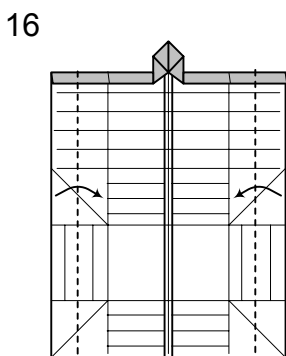
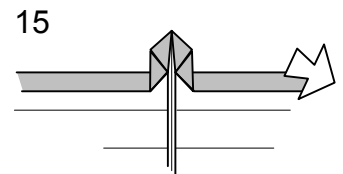

Fold creases 90° (not flat)

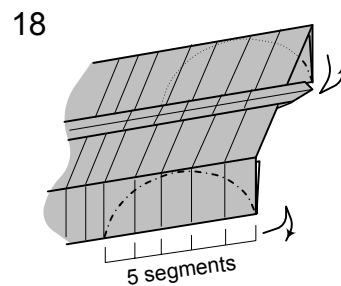

Pinch a curved mountain crease through both layers

Treasure chest

