

Teddy Bear

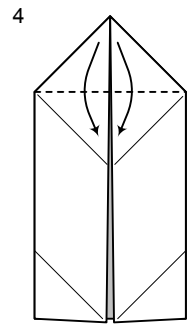

Fold the two points down

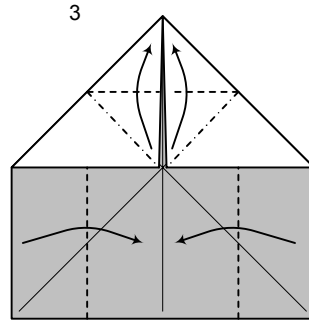
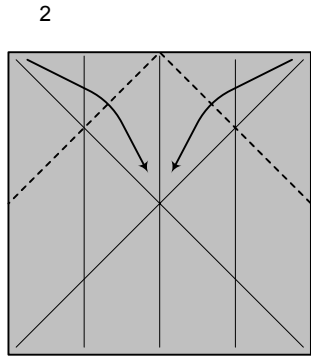
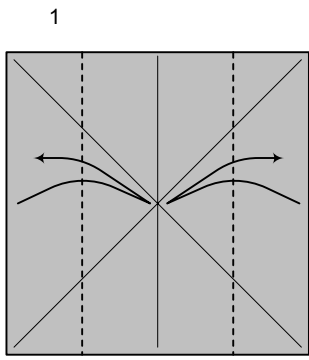
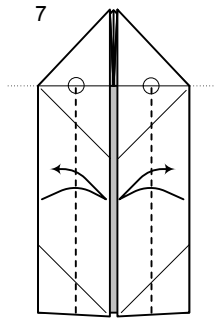
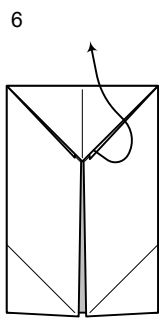
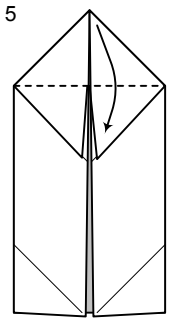

Crease through both layers only as far as circled points

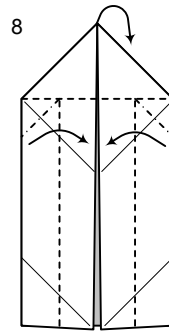

Fold edges in, lifting the top point toward you

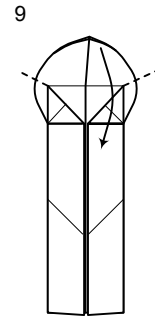

Flatten with a squash fold

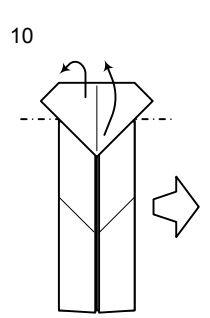

Swivel head behind

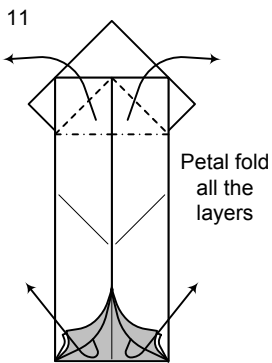

Petal fold all the layers

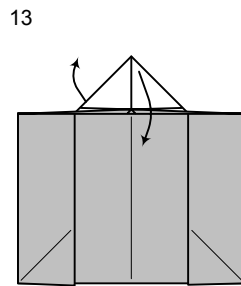
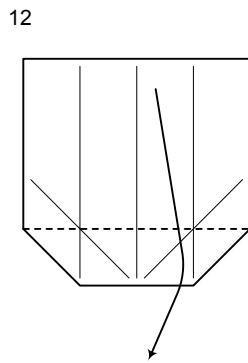

Swivel head to the front

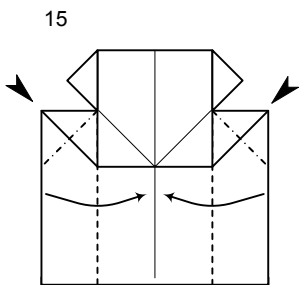
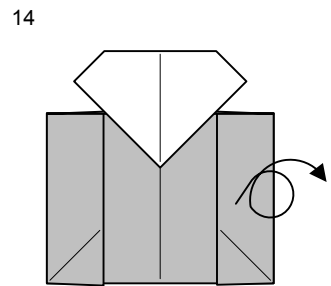

Squash fold while folding the double layers to the centre line

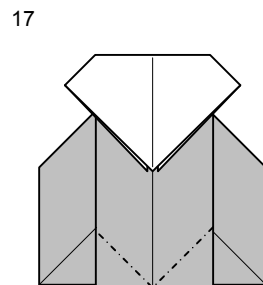
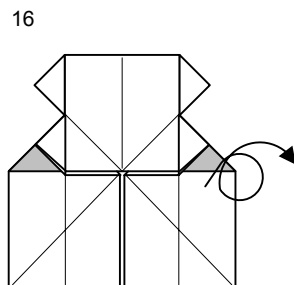

Make two inside reverse folds

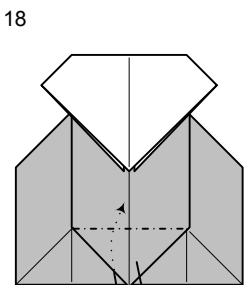

Tuck the point up inside the model

Teddy Bear

19

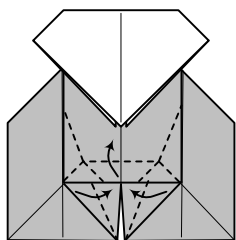

Petal fold

20

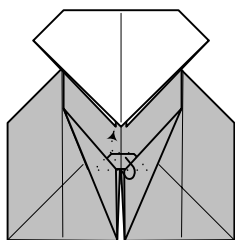

Reverse the point up inside the model

21

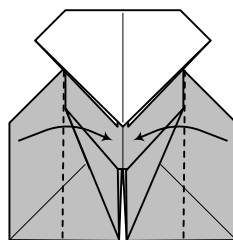

22

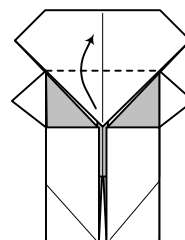

23

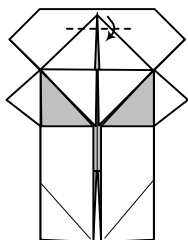

24

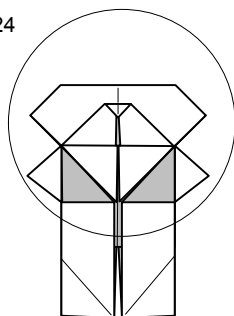

25

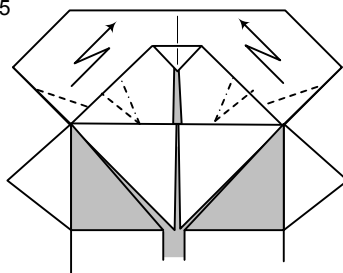

26

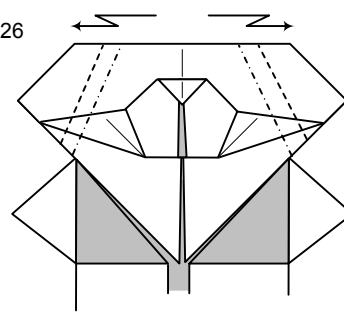

27

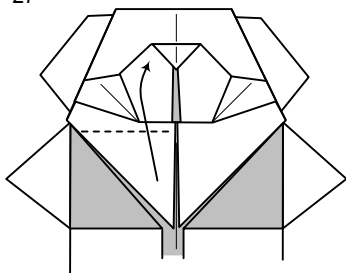

28

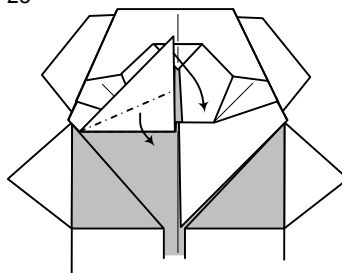

Squash fold

29

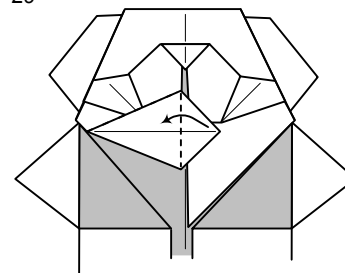

30

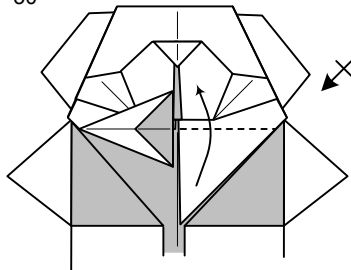

Repeat on the right side

31

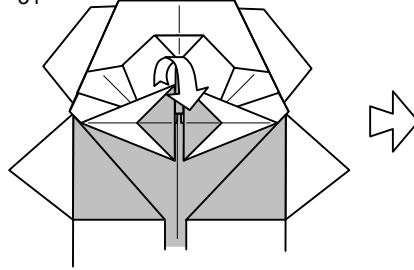

32

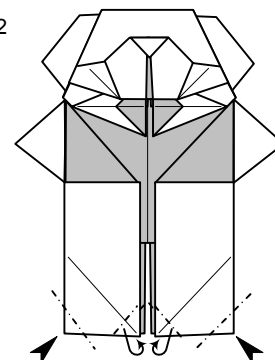

Round off the feet

33

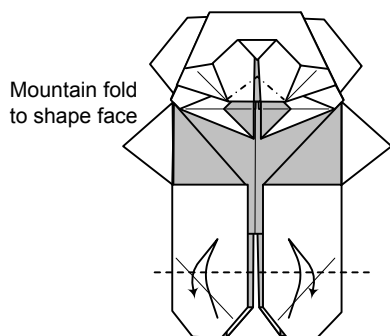

Mountain fold to shape face

34

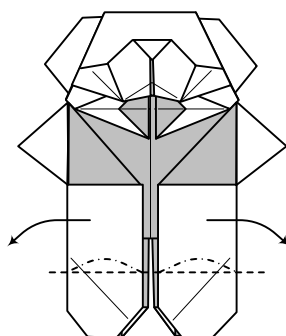

Crimp the feet while curving the body back slightly to make the legs '3D'

