

Cookie Monster

1

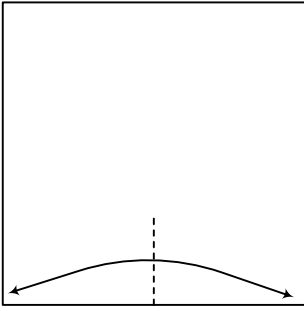

2

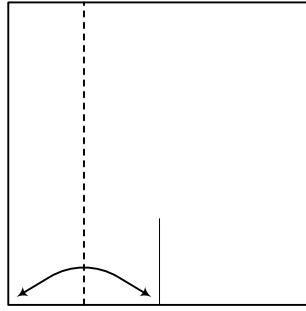

3

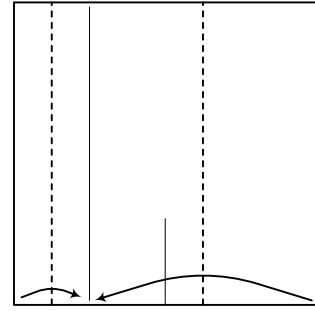

4

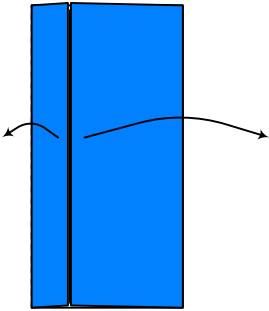

5

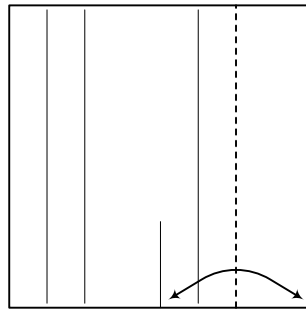

Repeat steps 2-4 on the opposite side

6

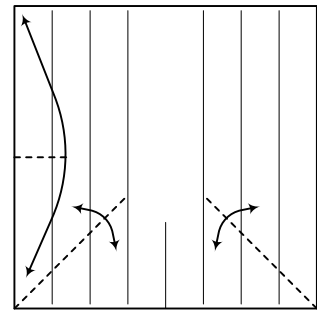

More pre-creasing

7

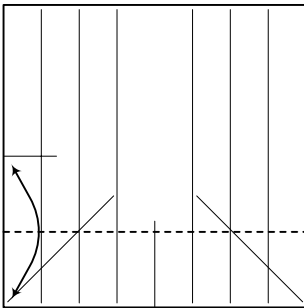

8

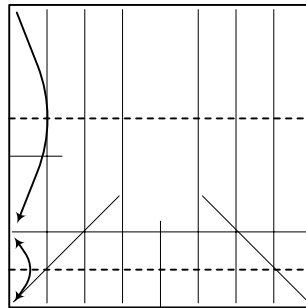

9

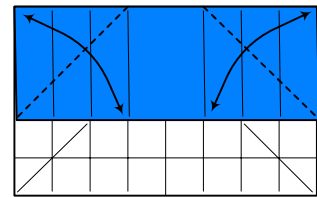

10

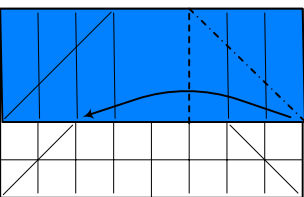

11

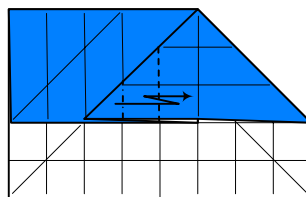

12

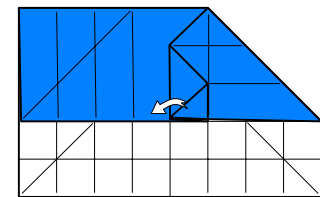

13

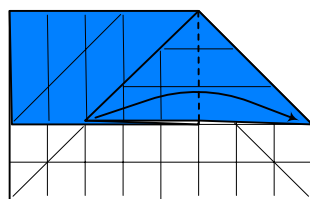

14

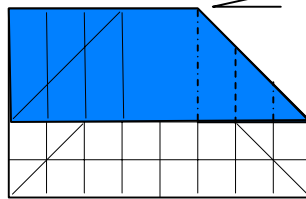

3 Inside reverse folds

15

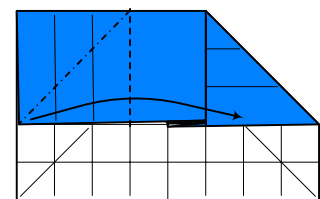

Repeat steps 10-14 on the left side

Cookie Monster

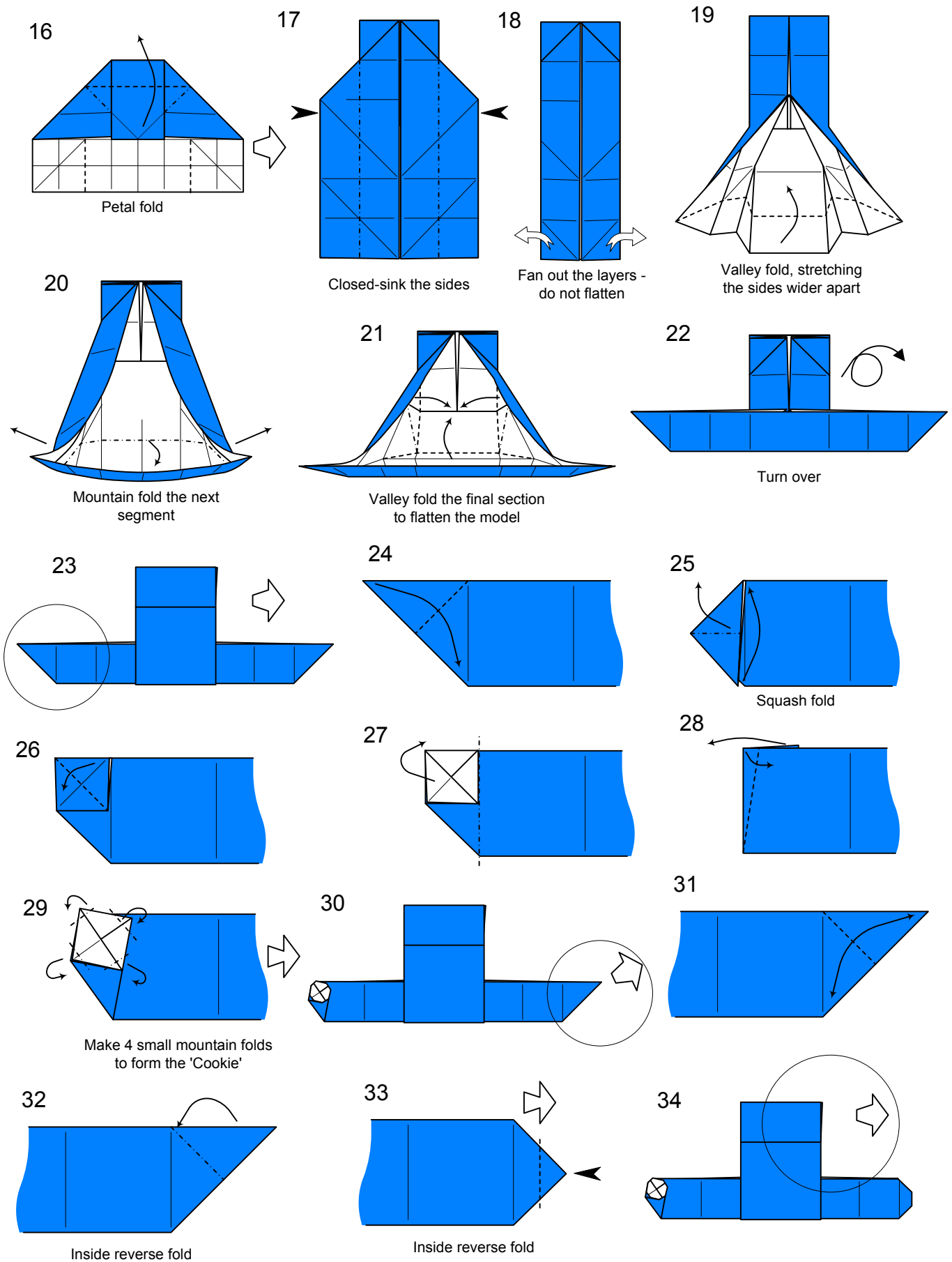

Cookie Monster

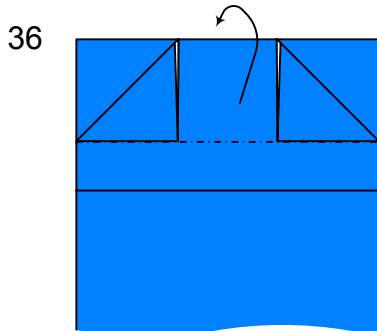
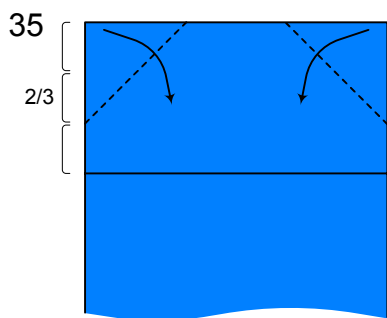

Fold a single layer down inside the model

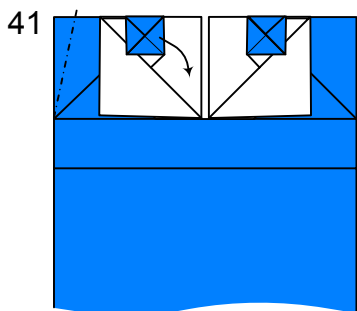
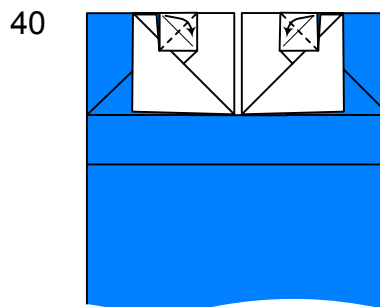
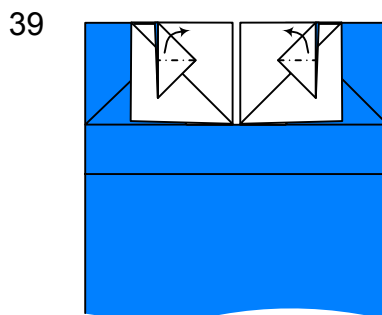
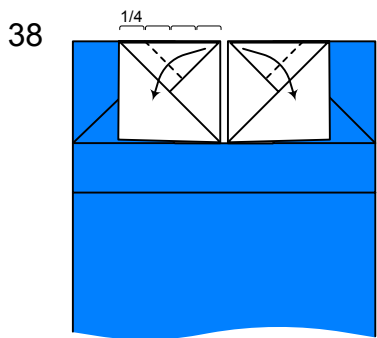
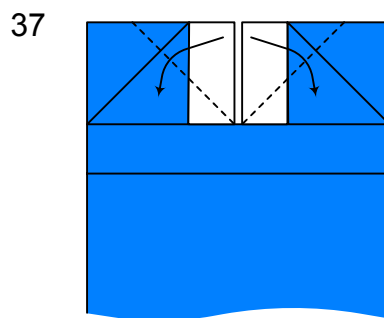

Swivel one of the pupils to make the eyes uneven

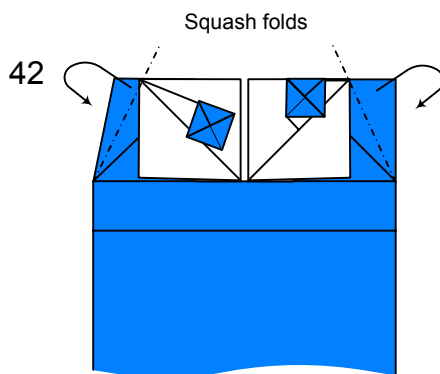

Squash folds

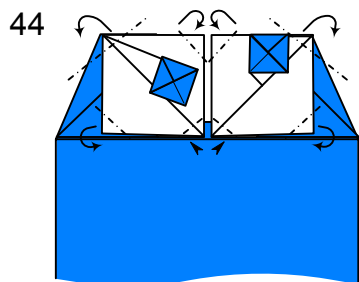
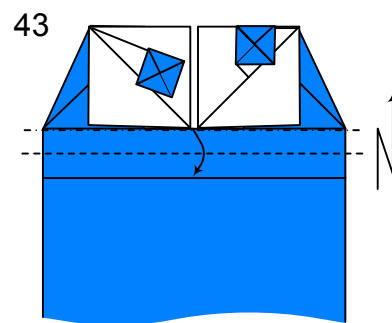

Round off the eyes

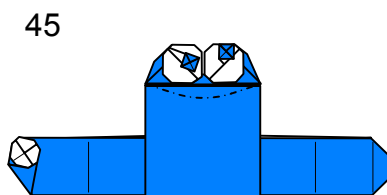

Make the body 3D adding a gentle curve to the mouth

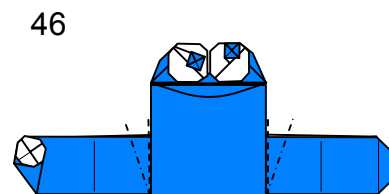

Simple valley and mountain folds to angle the arms

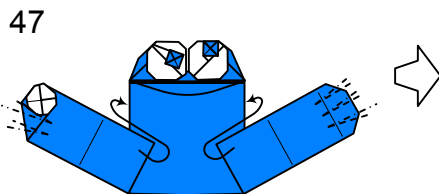

Tuck the corner of the arms inside the side of the model, pinch the hands to form fingers

