

# Black Belt in Origami

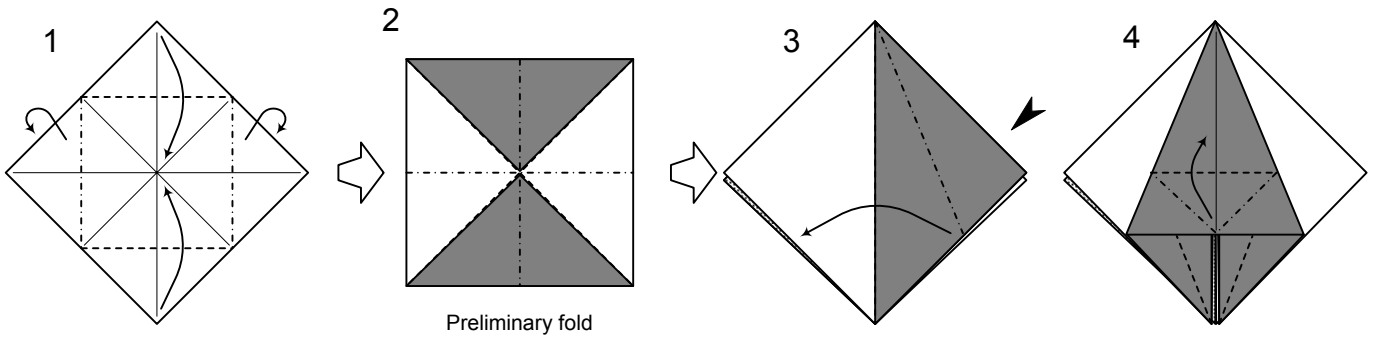

Preliminary fold

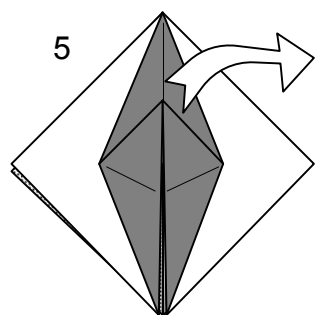

Pull out the loose paper (it helps if you unfold to step 4 first)

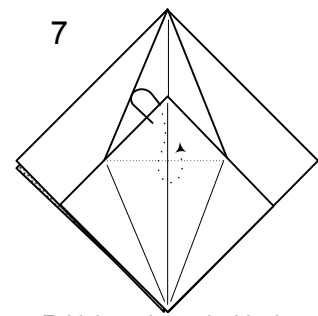
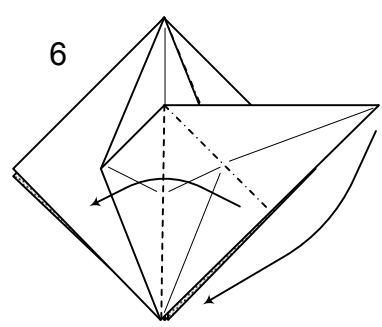

Fold the point up inside the model (you need to pull the model apart to do this)

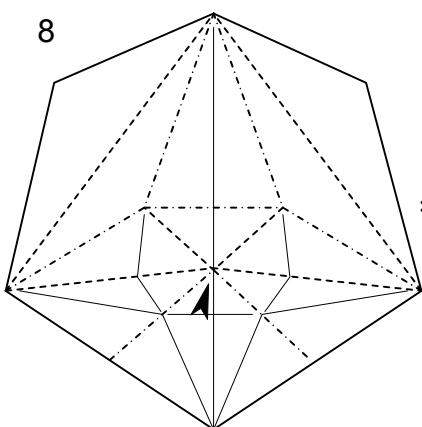

This is the half way stage

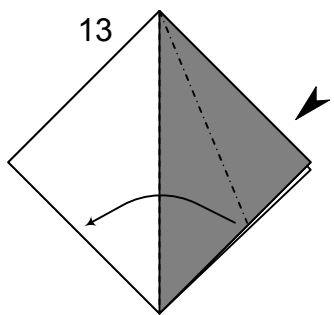
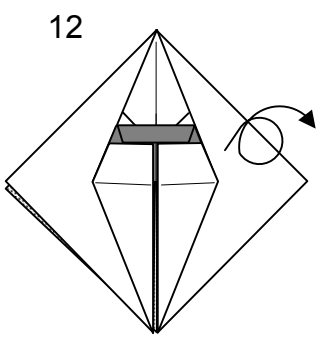
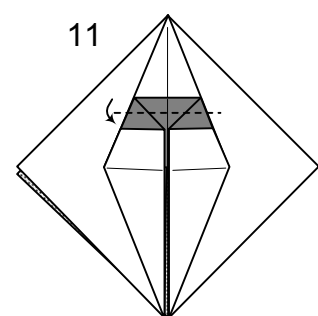
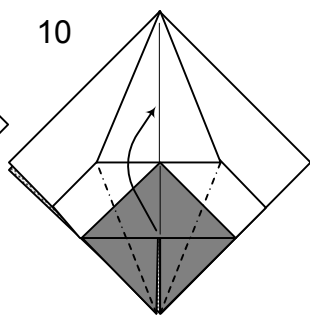
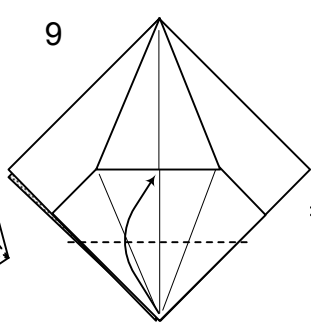

Repeat steps 3-8 on this side

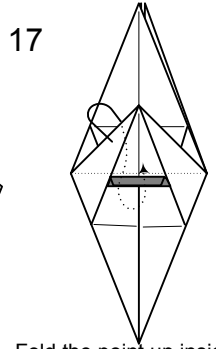
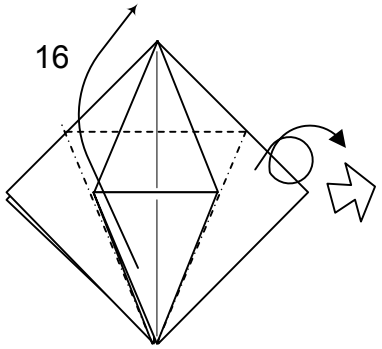
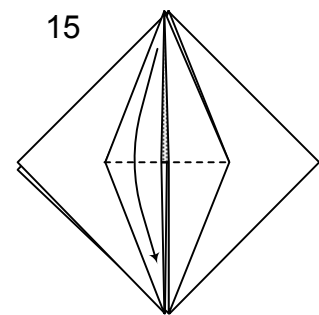
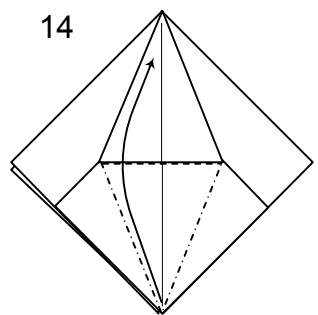

Fold the point up inside the model (much harder than step 7!)

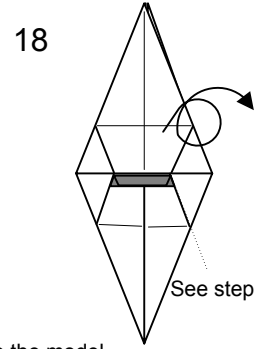

See step 20

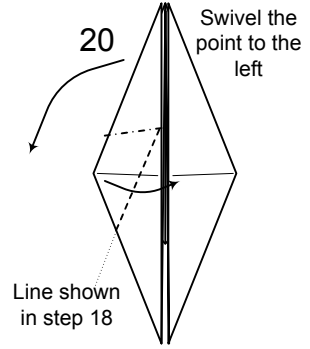
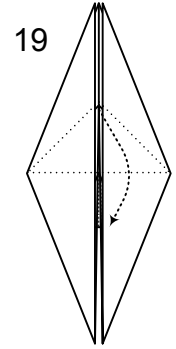

Line shown in step 18

Swivel the point to the left

# Black Belt in Origami

